

PARTS LIST						
ITEM	QTY	PART NO.	PART DESCRIPTION	LENGTH	UNIT WT.	NET WT.
1	1	X-210717	STANDOFF BRACKET WELDMENT		28.58	28.58
2	2	X-ATB	PIPE ATTACHMENT BRACKET		10.68	21.37
3	8	A5802	5/8" x 2" HDG A325 HEX BOLT		0.27	2.17
4	16	G58LW	5/8" HDG LOCKWASHER		0.03	0.42
5	16	G58NUT	5/8" HDG HEAVY 2H HEX NUT		0.13	2.08
6	4	X-UB1358	1/2" X 3-5/8" X 5-1/2" X 3" U-BOLT (HDG.)		0.77	3.09
6	4	X-UB1300	1/2" X 3" X 5" X 2" U-BOLT (HDG.)		0.70	2.80
6	4	X-UB1212	1/2" X 2-1/2" X 4-1/2" X 2" U-BOLT (HDG.)		0.63	2.52
7	8	G12FW	1/2" HDG USS FLATWASHER		0.03	0.27
8	8	G12LW	1/2" HDG LOCKWASHER		0.01	0.11
9	8	G12NUT	1/2" HDG HEAVY 2H HEX NUT		0.07	0.57
10	4	G58R-18	5/8" x 18" THREADED ROD (HDG.)		1.57	6.27
11	2	X-214166	V-ANGLE PIPE CLAMP	14 in	8.58	17.15
12	2	X-214167	BACKING ANGLE PIPE CLAMP	14 in	8.77	17.54
					TOTAL WT. #	103.28

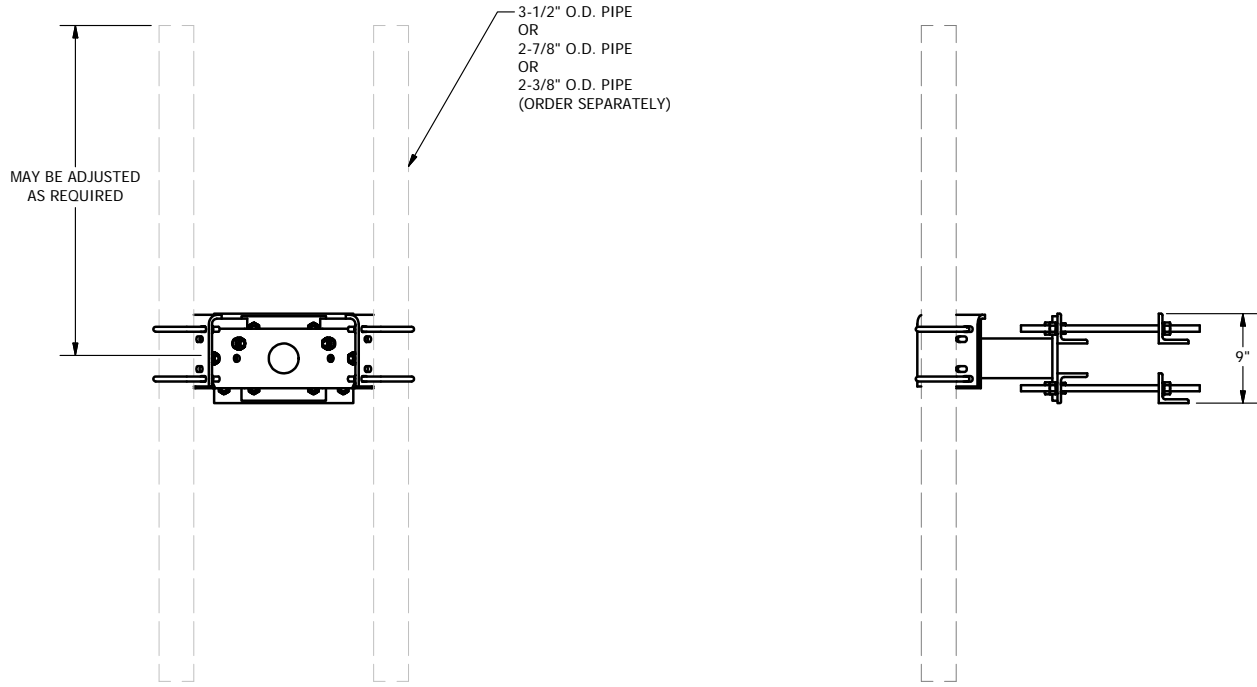

NOTE:
REFERENCE VMI P/N
217928 & 213158

REV	DESCRIPTION OF REVISIONS	CPD	BY	DATE
A	REPLACED X-210746 WITH X-ATB	4779	CEK	1/5/2012
REVISION HISTORY				

TOLERANCE NOTE
TOLERANCES ON DIMENSIONS, UNLESS OTHERWISE NOTED ARE: SAWED, SHEARED AND GAS CUT EDGES (± 0.030 "
DRILLED AND GAS CUT HOLES (± 0.030 " - NO CONING OF HOLES
LASER CUT EDGES AND HOLES (± 0.010 " - NO CONING OF HOLES
BENDS ARE $\pm 1/2$ DEGREE - ALL OTHER MACHINING (± 0.030 "
ALL OTHER ASSEMBLY (± 0.060 ")

PROPRIETARY NOTE
 THE DATA AND TECHNIQUES CONTAINED IN THIS DRAWING ARE PROPRIETARY INFORMATION OF VALMONT INDUSTRIES AND CONSIDERED A TRADE SECRET. ANY USE OR DISCLOSURE WITHOUT THE CONSENT OF VALMONT INDUSTRIES IS STRICTLY PROHIBITED.

DESCRIPTION	
DUAL ANTENNA MOUNT ASSEMBLY	
2-1/2" TO 10-3/4" ROUND LEG	
2" TO 8" EQUAL ANGLE LEG	
DRAWN BY	CPD NO.
CEK	4779
ENG. APPROVAL	CHECKED BY
	BMC
DRAWING USAGE	CUSTOMER
	1/6/2012

<p>Engineering Support Team: 1-888-753-7446</p> <p>A valmont COMPANY</p>	Locations: New York, NY Atlanta, GA Los Angeles, CA Plymouth, IN Salem, OR Dallas, TX
	<p>PART NO. CWT8-LL</p> <p>DWG. NO. CWT8-LL</p>