

PARTS LIST						
ITEM	QTY	PART NO.	PART DESCRIPTION	LENGTH	UNIT WT.	NET WT.
1	2	X-SP126	BASE SHOE PLATE PIPE COLUMN		92.98	185.97
2	4	X-UB1358	1/2" X 3-5/8" X 5-1/2" X 3" U-BOLT (HDG.)		0.77	3.09
3	8	G12FW	1/2" HDG USS FLATWASHER		0.03	0.27
4	8	G12LW	1/2" HDG LOCKWASHER		0.01	0.11
5	8	G12NUT	1/2" HDG HEAVY 2H HEX NUT		0.07	0.57
6	2	PC312	3-1/2" FENCE POST CAP		0.59	1.17
7	4	SPLICE	SPLICE FOR GRIP STRUT	7 3/8 in	0.53	2.10
8	28	G38FW	3/8" HDG USS FLATWASHER		0.01	0.33
9	20	G3803	3/8" x 3" HDG HEX BOLT GR5		0.12	2.43
10	38	G38LW	3/8" HDG LOCKWASHER		0.01	0.25
11	38	G38NUT	3/8" HDG HEAVY 2H HEX NUT		0.03	1.29
12	8	SWA585	5/8" X 5" STAINLESS WEDGE ANCHOR		0.61	4.85
13	1	GRS24	24" X 10' GRIP SPAN BRIDGE CHANNEL		67.98	67.98
14	2	HHD24	24" UNIVERSAL CANTILEVER		14.10	28.20
15	3	TAB	TRAPEZE CENTER SUPPORT BAR		5.05	15.14
16	12	SQW38	3/8" SQUARE WASHER (GALV.)	2 in	0.27	3.28
17	9	AB24	24" ANGLE BRACKET		2.91	26.19
18	18	G38114	3/8" x 1-1/4" HDG HEX BOLT GR5		0.06	1.13
					TOTAL WT. #	332.07

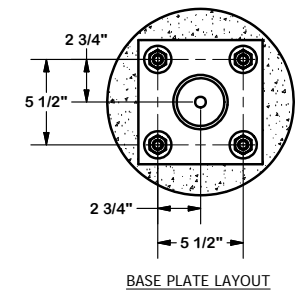
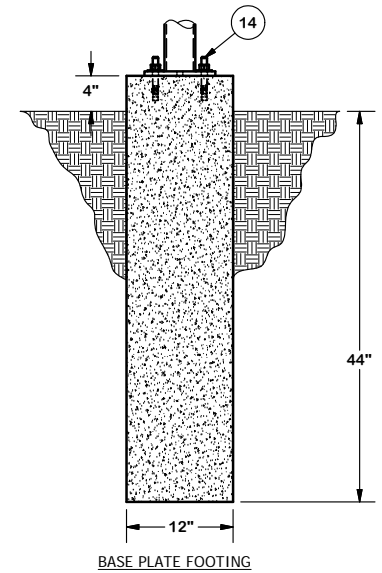

**TOLERANCE NOTES**  
 TOLERANCES ON DIMENSIONS, UNLESS OTHERWISE NOTED ARE:  
 SAWED, SHEARED AND GAS CUT EDGES ( $\pm 0.030"$ )  
 DRILLED AND GAS CUT HOLES ( $\pm 0.030"$ ) - NO CONING OF HOLES  
 LASER CUT EDGES AND HOLES ( $\pm 0.010"$ ) - NO CONING OF HOLES  
 BENDS ARE  $\pm 1/2$  DEGREE  
 ALL OTHER MACHINING ( $\pm 0.030"$ )  
 ALL OTHER ASSEMBLY ( $\pm 0.060"$ )

**PROPRIETARY NOTE:**  
 THE DATA AND TECHNIQUES CONTAINED IN THIS DRAWING ARE PROPRIETARY INFORMATION OF VALMONT INDUSTRIES AND CONSIDERED A TRADE SECRET. ANY USE OR DISCLOSURE WITHOUT THE CONSENT OF VALMONT INDUSTRIES IS STRICTLY PROHIBITED.

DESCRIPTION 24" GRIP-SPAN ICE BRIDGE KIT WITH TRIPLE-TEE TRAPEZE BASE SHOE		
CPD NO.	DRAWN BY CEK 9/7/2011	ENG. APPROVAL
CLASS	DRAWING USAGE CUSTOMER	CHECKED BY KAC 6/13/2012

 <b>A valmont COMPANY</b>	Locations: New York, NY Atlanta, GA Los Angeles, CA Plymouth, IN Salem, OR Dallas, TX
	Engineering Support Team: 1-888-753-7446
PART NO. IB24B-T3	DWG. NO. IB24B-T3