

PARTS LIST						
ITEM	QTY	PART NO.	PART DESCRIPTION	LENGTH	UNIT WT.	NET WT.
1	4	X-UB1358	1/2" X 3-5/8" X 5-1/2" X 3" U-BOLT (HDG.)		0.66	2.63
2	8	G12FW	1/2" HDG USS FLATWASHER		0.03	0.27
3	8	G12LW	1/2" HDG LOCKWASHER		0.01	0.11
4	8	G12NUT	1/2" HDG HEAVY 2H HEX NUT		0.07	0.57
5	2	PC312	3-1/2" FENCE POST CAP		0.59	1.17
6	4	SPLICE	SPLICE FOR GRIP STRUT	7 3/8 in	0.53	2.10
7	16	G38FW	3/8" HDG USS FLATWASHER		0.01	0.19
8	8	G3803	3/8" x 3" HDG HEX BOLT GR5		0.12	0.97
9	8	G38LW	3/8" HDG LOCKWASHER		0.01	0.05
10	8	G38NUT	3/8" HDG HEAVY 2H HEX NUT		0.03	0.27
11	1	GRS24	24" X 10' GRIP SPAN BRIDGE CHANNEL		67.98	67.98
12	2	HHD24	24" UNIVERSAL CANTILEVER		14.10	28.20
13	2	P3216	3" SCH. 40 PIPE (3.5" O.D. x 0.216" WALL) A500	216 in	136.68	273.37
<b>TOTAL WT. #</b>						<b>376.89</b>

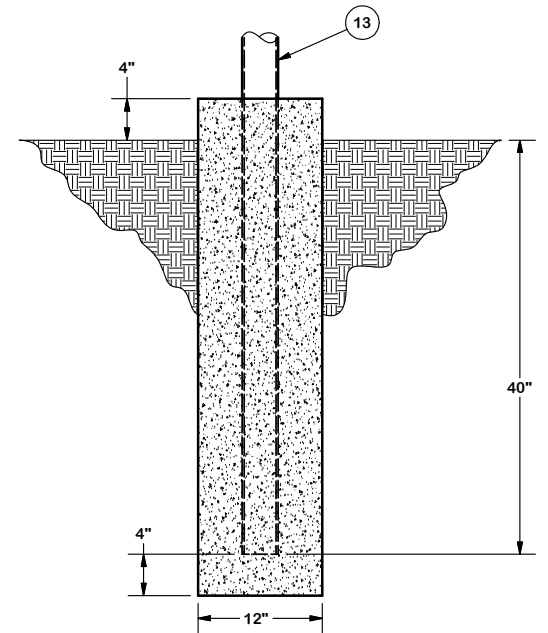

DIRECT BURIAL FOOTING

**TOLERANCE NOTES**

TOLERANCES ON DIMENSIONS, UNLESS OTHERWISE NOTED ARE:  
 SAWED, SHEARED AND GAS CUT EDGES ( $\pm 0.030"$ )  
 DRILLED AND GAS CUT HOLES ( $\pm 0.030"$ ) - NO CONING OF HOLES  
 LASER CUT EDGES AND HOLES ( $\pm 0.010"$ ) - NO CONING OF HOLES  
 BENDS ARE  $\pm 1/2$  DEGREE  
 ALL OTHER MACHINING ( $\pm 0.030"$ )  
 ALL OTHER ASSEMBLY ( $\pm 0.060"$ )

PROPRIETARY NOTE:  
 THE DATA AND TECHNIQUES CONTAINED IN THIS DRAWING ARE PROPRIETARY INFORMATION OF VALMONT INDUSTRIES AND CONSIDERED A TRADE SECRET. ANY USE OR DISCLOSURE WITHOUT THE CONSENT OF VALMONT INDUSTRIES IS STRICTLY PROHIBITED.

DESCRIPTION  
**CANTILEVER GRIP-SPAN ICE BRIDGE KIT  
 WITH NO TRAPEZE  
 18' DIRECT BURIAL**

CPD NO.	DRAWN BY	ENG. APPROVAL
CLASS	DRAWING USAGE	CHECKED BY
81	02	CUSTOMER
		BMC 8/15/2011

**SITE PRO 1**  
 Engineering Support Team:  
 1-888-753-7446

Locations:  
 New York, NY  
 Atlanta, GA  
 Los Angeles, CA  
 Plymouth, IN  
 Salem, OR  
 Dallas, TX

A valmont COMPANY

PART NO.	IB24D-216	PAGE
DWG. NO.	IB24D-216	1 OF 1