

PARTS LIST						
ITEM	QTY	PART NO.	PART DESCRIPTION	LENGTH	UNIT WT.	NET WT.
4	4	X-UB1358	1/2" X 3-5/8" X 5-1/2" X 3" U-BOLT (HDG.)		0.77	3.09
5	8	G12FW	1/2" HDG USS FLATWASHER		0.03	0.27
6	8	G12LW	1/2" HDG LOCKWASHER		0.01	0.11
7	8	G12NUT	1/2" HDG HEAVY 2H HEX NUT		0.07	0.57
8	2	PC312	3-1/2" FENCE POST CAP		0.59	1.17
9	4	SPLICE	SPLICE FOR GRIP STRUT	7 3/8 in	0.53	2.10
10	28	G38FW	3/8" HDG USS FLATWASHER		0.01	0.33
11	20	G3803	3/8" x 3" HDG HEX BOLT GR5		0.12	2.43
12	38	G38LW	3/8" HDG LOCKWASHER		0.01	0.25
13	38	G38NUT	3/8" HDG HEAVY 2H HEX NUT		0.03	1.29
15	1	GRS24	24" X 10' GRIP SPAN BRIDGE CHANNEL		67.98	67.98
16	2	HHD24	24" UNIVERSAL CANTILEVER		14.10	28.20
17	3	TAB	TRAPEZE CENTER SUPPORT BAR		5.05	15.14
18	12	SQW38	3/8" SQUARE WASHER (GALV.)	2 in	0.27	3.28
19	2	P3216	3" SCH. 40 PIPE (3.5" O.D. x 0.216" WALL) A500	216 in	136.68	273.37
20	18	G38114	3/8" x 1-1/4" HDG HEX BOLT GR5		0.06	1.13
21	9	AB24	24" ANGLE BRACKET		2.91	26.19
					TOTAL WT. #	423.48

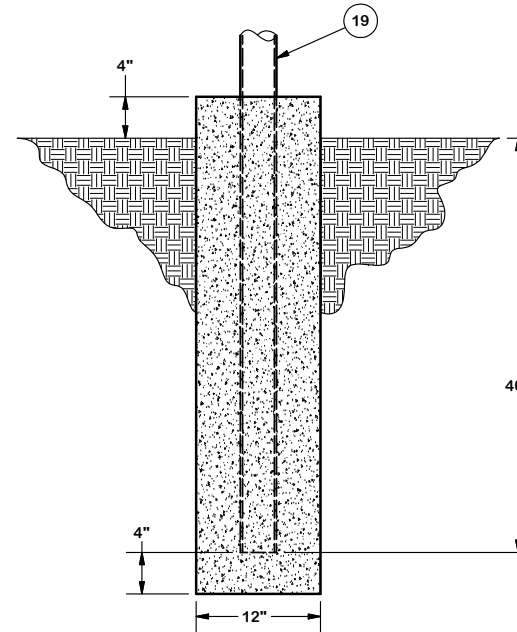

DIRECT BURIAL FOOTING

**TOLERANCE NOTES**

TOLERANCES ON DIMENSIONS, UNLESS OTHERWISE NOTED ARE:  
 SAWED, SHEARED AND GAS CUT EDGES ( $\pm 0.030"$ )  
 DRILLED AND GAS CUT HOLES ( $\pm 0.030"$ ) - NO CONING OF HOLES  
 LASER CUT EDGES AND HOLES ( $\pm 0.010"$ ) - NO CONING OF HOLES  
 BENDS ARE  $\pm 1/2$  DEGREE  
 ALL OTHER MACHINING ( $\pm 0.030"$ )  
 ALL OTHER ASSEMBLY ( $\pm 0.060"$ )

PROPRIETARY NOTE:  
 THE DATA AND TECHNIQUES CONTAINED IN THIS DRAWING ARE PROPRIETARY INFORMATION OF VALMONT INDUSTRIES AND CONSIDERED A TRADE SECRET. ANY USE OR DISCLOSURE WITHOUT THE CONSENT OF VALMONT INDUSTRIES IS STRICTLY PROHIBITED.

DESCRIPTION

24" GRIP-SPAN ICE BRIDGE KIT  
 WITH TRIPLE-TEE TRAPEZE  
 18' DIRECT BURIAL



Engineering Support Team:  
 1-888-753-7446

Locations:  
 New York, NY  
 Atlanta, GA  
 Los Angeles, CA  
 Plymouth, IN  
 Salem, OR  
 Dallas, TX

CPD NO.	DRAWN BY CEK	9/7/2011	ENG. APPROVAL
CLASS	SUB	DRAWING USAGE CUSTOMER	CHECKED BY KAC 6/13/2012

PART NO.	IB24D-216T3
DWG. NO.	IB24D-216T3