

PARTS LIST						
ITEM	QTY	PART NO.	PART DESCRIPTION	LENGTH	UNIT WT.	NET WT.
1	1	GRS24	24" X 10' GRIP SPAN BRIDGE CHANNEL		67.98	67.98
2	2	HHD24	24" UNIVERSAL CANTILEVER		14.10	28.20
3	4	X-UB1358	1/2" X 3-5/8" X 5-1/2" X 3" U-BOLT (HDG.)		0.66	2.63
4	8	G12FW	1/2" HDG USS FLATWASHER		0.03	0.27
5	8	G12LW	1/2" HDG LOCKWASHER		0.01	0.11
6	8	G12NUT	1/2" HDG HEAVY 2H HEX NUT		0.07	0.57
7	2	PC312	3-1/2" FENCE POST CAP		0.59	1.17
8	4	SPLICE	SPLICE FOR GRIP STRUT	7 3/8 in	0.53	2.10
9	2	P3160	3" SCH. 40 PIPE (3.5" O.D. x 0.216" WALL) A500	160 in	101.25	202.50
10	28	G38FW	3/8" HDG USS FLATWASHER		0.01	0.33
11	14	G3803	3/8" x 3" HDG HEX BOLT GR5		0.12	1.70
12	14	G38LW	3/8" HDG LOCKWASHER		0.01	0.09
13	14	G38NUT	3/8" HDG HEAVY 2H HEX NUT		0.03	0.47
14	3	X-VT18	18" UNIVERSAL VERTICAL TRAPEZE		5.97	17.92
15	6	SQW38	3/8" SQUARE WASHER (GALV.)	2 in	0.27	1.64
					TOTAL WT. #	328.14

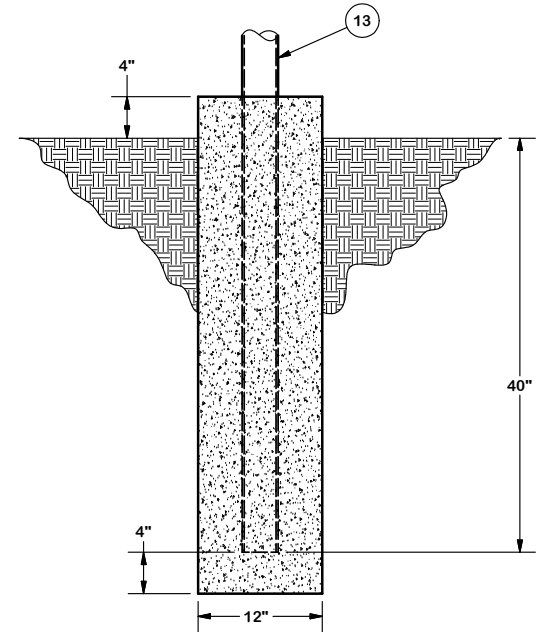

DIRECT BURIAL FOOTING

TOLERANCE NOTES

TOLERANCES ON DIMENSIONS, UNLESS OTHERWISE NOTED ARE:
 SAWED, SHEARED AND GAS CUT EDGES ($\pm 0.030"$)
 DRILLED AND GAS CUT HOLES ($\pm 0.030"$) - NO CONING OF HOLES
 LASER CUT EDGES AND HOLES ($\pm 0.010"$) - NO CONING OF HOLES
 BENDS ARE $\pm 1/2$ DEGREE
 ALL OTHER MACHINING ($\pm 0.030"$)
 ALL OTHER ASSEMBLY ($\pm 0.060"$)

PROPRIETARY NOTE:
 THE DATA AND TECHNIQUES CONTAINED IN THIS DRAWING ARE PROPRIETARY INFORMATION OF VALMONT INDUSTRIES AND CONSIDERED A TRADE SECRET. ANY USE OR DISCLOSURE WITHOUT THE CONSENT OF VALMONT INDUSTRIES IS STRICTLY PROHIBITED.

DESCRIPTION
 24" GRIP-SPAN ICE BRIDGE KIT WITH VERTICAL T-BRACKET

CPD NO.	DRAWN BY CEK	ENG. APPROVAL
CLASS 81	SUB 02	DRAWING USAGE CUSTOMER
		CHECKED BY BMC
		8/15/2011

SITE PRO 1
 A valmont COMPANY
 Engineering Support Team:
 1-888-753-7446
 Locations:
 New York, NY
 Atlanta, GA
 Los Angeles, CA
 Plymouth, IN
 Salem, OR
 Dallas, TX

PART NO.	IB24D-V
DWG. NO.	IB24D-V