

PARTS LIST						
ITEM	QTY	PART NO.	PART DESCRIPTION	LENGTH	UNIT WT.	NET WT.
1	2	HHD12	12" CANTILEVER WELDMENT		8.01	16.02
2	3	X-232696	BALLAST TRAY WELDMENT - SITE PRO 1		66.53	199.60
3	4	X-232698	TRPD-HD SUPPORT PLATE - SITE PRO 1		8.72	34.89
4	2	P2126	2-3/8" OD X 126" SCH 40 GALVANIZED PIPE	126 in	40.75	81.50
5	4	P296	2-3/8" X 96" SCH. 40 GALVANIZED PIPE	96 in	30.76	123.03
6	6	SCX1	CROSSOVER PLATE 2-3/8" X 2-3/8"		3.71	22.25
7	8	X-115765	5" V-CLAMP		1.03	8.20
8	24	X-100064	CLAMP (S) (4" V-CLAMP) GALVANIZED		0.91	21.91
9	28	X-UB1212	1/2" X 2-1/2" X 4-1/2" X 2" U-BOLT (HDG.)		0.73	20.49
10	4	G1205	1/2" x 5" HDG HEX BOLT GR5 FULL THREAD	5 in	0.33	1.30
11	28	G12045	1/2" x 4.5" HDG HEX BOLT GR5 FULL THREAD	4 1/2 in	0.30	8.34
13	104	G12FW	1/2" HDG USS FLATWASHER		0.03	3.54
14	88	G12LW	1/2" HDG LOCKWASHER		0.01	1.22
15	88	G12NUT	1/2" HDG HEAVY 2H HEX NUT		0.07	6.30
16	4	X-UB3212	3/8" X 2-1/2" X 3-5/8" X 1-3/4" U-BOLT (HDG.)		0.29	1.16
17	8	G38FW	3/8" HDG USS FLATWASHER		0.01	0.09
18	8	G38LW	3/8" HDG LOCKWASHER		0.01	0.05
19	8	G38NUT	3/8" HDG HEAVY 2H HEX NUT		0.03	0.27
TOTAL WT. #					547.20	

- 15
- 14
- 13 X2
- 11
- 8

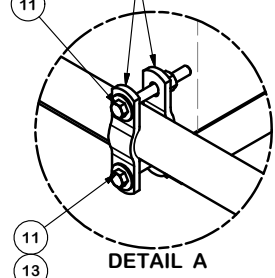

- 19 X2
- 18 X2
- 17 X2
- 16
- 15 X2
- 14 X2
- 13 X2
- 9

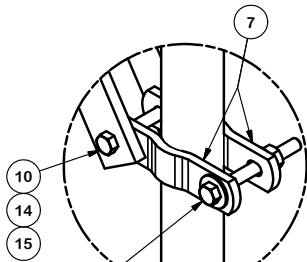
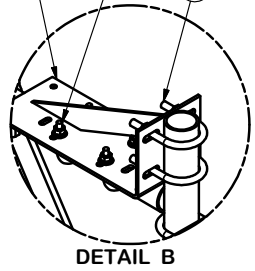

- 11
- 13
- 14
- 15

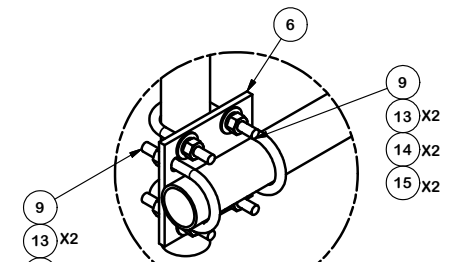

- 9
- 13 X2
- 14 X2
- 15 X2

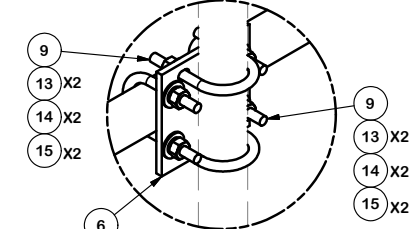

- 9
- 13 X2
- 14 X2
- 15 X2

TOLERANCE NOTES
 TOLERANCES ON DIMENSIONS, UNLESS OTHERWISE NOTED ARE:
 SAWED, SHEARED AND GAS CUT EDGES ($\pm 0.030"$)
 DRILLED AND GAS CUT HOLES ($\pm 0.030"$) - NO CONING OF HOLES
 LASER CUT EDGES AND HOLES ($\pm 0.010"$) - NO CONING OF HOLES
 BENDS ARE $\pm 1/2$ DEGREE
 ALL OTHER MACHINING ($\pm 0.030"$)
 ALL OTHER ASSEMBLY ($\pm 0.060"$)

PROPRIETARY NOTE:
 THE DATA AND TECHNIQUES CONTAINED IN THIS DRAWING ARE PROPRIETARY INFORMATION OF VALMONT INDUSTRIES AND CONSIDERED A TRADE SECRET. ANY USE OR DISCLOSURE WITHOUT THE CONSENT OF VALMONT INDUSTRIES IS STRICTLY PROHIBITED.

DESCRIPTION		HEAVY DUTY FLUSHMOUNT ROOFTOP OVERHANG LARGE TRAY	
CPD NO.	DRAWN BY	ENG. APPROVAL	
	CEK 8/20/2014		
CLASS	SUB	DRAWING USAGE	CHECKED BY
81	02	CUSTOMER	BMC 1/16/2015

 A valmont COMPANY	Locations: New York, NY Atlanta, GA Los Angeles, CA Plymouth, IN Salem, OR Dallas, TX
	Engineering Support Team: 1-888-753-7446
PART NO.	RFO-LHD
DWG. NO.	RFO-LHD

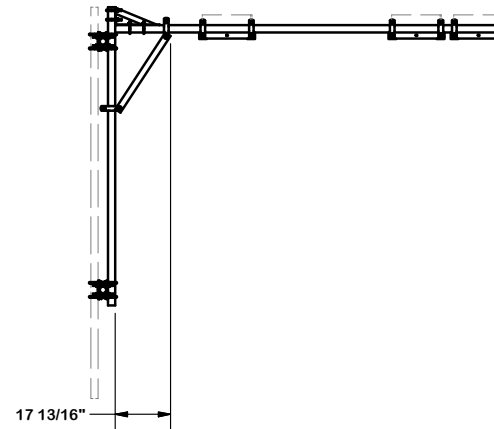
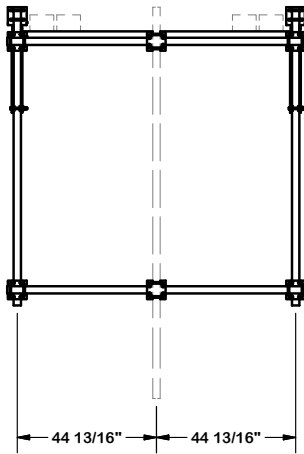
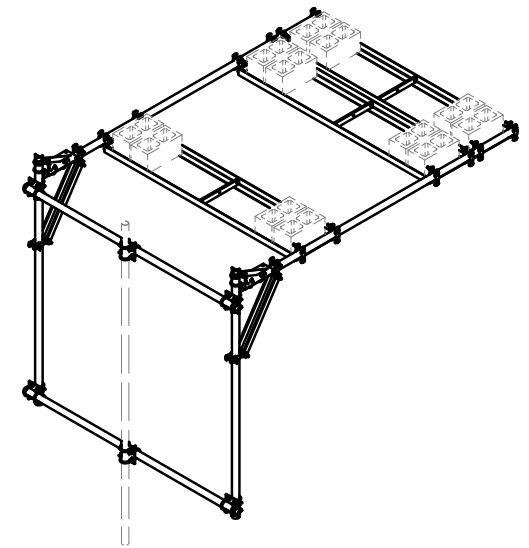
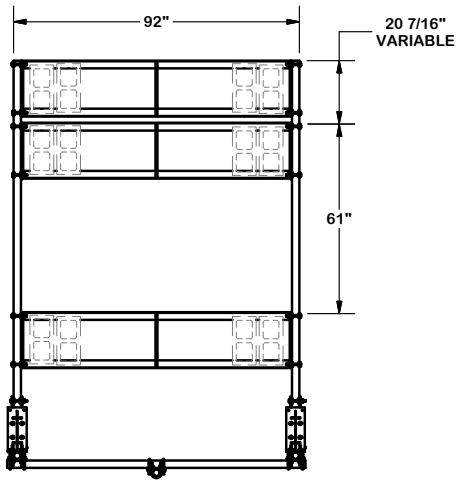

TOLERANCE NOTES

TOLERANCES ON DIMENSIONS, UNLESS OTHERWISE NOTED ARE:
 SAWED, SHEARED AND GAS CUT EDGES ($\pm 0.030"$)
 DRILLED AND GAS CUT HOLES ($\pm 0.030"$) - NO CONING OF HOLES
 LASER CUT EDGES AND HOLES ($\pm 0.010"$) - NO CONING OF HOLES
 BENDS ARE $\pm 1/2$ DEGREE
 ALL OTHER MACHINING ($\pm 0.030"$)
 ALL OTHER ASSEMBLY ($\pm 0.060"$)

PROPRIETARY NOTE:
 THE DATA AND TECHNIQUES CONTAINED IN THIS DRAWING ARE PROPRIETARY INFORMATION OF VALMONT INDUSTRIES AND CONSIDERED A TRADE SECRET. ANY USE OR DISCLOSURE WITHOUT THE CONSENT OF VALMONT INDUSTRIES IS STRICTLY PROHIBITED.

DESCRIPTION

HEAVY DUTY FLUSHMOUNT
 ROOFTOP OVERHANG
 LARGE TRAY



Engineering
 Support Team:
 1-888-753-7446

Locations:
 New York, NY
 Atlanta, GA
 Los Angeles, CA
 Plymouth, IN
 Salem, OR
 Dallas, TX

CPD NO.	DRAWN BY	ENG. APPROVAL
81	CEK 8/20/2014	
CLASS	DRAWING USAGE	CHECKED BY
81	CUSTOMER	BMC 1/16/2015

PART NO.	RFO-LHD
DWG. NO.	RFO-LHD