

PARTS LIST

ITEM	QTY	PART NO.	PART DESCRIPTION	LENGTH	UNIT WT.	NET WT.
1	6	X-LWRM	RING MOUNT WELDMENT		68.81	412.85
2	66	G58LW	5/8" HDG LOCKWASHER		0.03	1.72
3	60	A58NUT	5/8" HDG A325 HEX NUT		0.13	7.79
4	18	G58R-24	5/8" x 24" THREADED ROD (HDG.)		2.09	37.63
4	18	G58R-48	5/8" x 48" THREADED ROD (HDG.)		4.18	75.27
5	24	A58234	5/8" x 2-3/4" HDG A325 HEX BOLT	2 3/4 in	0.36	8.54
6	24	A58FW	5/8" HDG A325 FLATWASHER		0.03	0.82
7	36	X-UB1306	1/2" X 3-5/8" X 6" X 3" U-BOLT (HDG.)		0.83	29.82
8	264	G12FW	1/2" HDG USS FLATWASHER	3/32 in	0.03	9.00
9	252	G12LW	1/2" HDG LOCKWASHER	1/8 in	0.01	3.50
10	252	G12NUT	1/2" HDG HEAVY 2H HEX NUT		0.07	18.05
11	12	P3096	2-7/8" X 96" (2-1/2" SCH 40) GALVANIZED PIPE	96 in	49.24	590.88
12	48	X-UB1300	1/2" X 3" X 5" X 2" U-BOLT (HDG.)		0.70	33.45
13	3	P3174	3-1/2" X 174" SCH 40 GALVANIZED PIPE	174 in	109.97	329.90
14	3	X-SV196L	LONG PLATFORM WELDMENT		230.94	692.81
15	3	P2174	2-3/8" OD X 174" SCH 40 GALVANIZED PIPE	174 in	55.75	167.24
16	12	SCX2	CROSSOVER PLATE	7 in	4.80	57.56
17	36	X-UB1212	1/2" X 2-1/2" X 4-1/2" X 2" U-BOLT (HDG.)		0.63	22.51
18	15	SCX4	CROSSOVER PLATE	8 1/2 in	6.02	90.32
19	6	G58NUT	5/8" HDG HEAVY 2H HEX NUT		0.13	0.78
20	6	X-254923	PLATFORM REINFORCEMENT KIT ANGLE	84 in	22.83	137.00
21	6	X-TBW	T-BRACKET WELDMENT		13.60	81.60
22	6	G5802	5/8" x 2" HDG HEX BOLT GR5		0.27	1.62
23	12	G12065	1/2" x 6-1/2" HDG HEX BOLT GR5 FULL THREAD	5 1/2 in	0.41	4.91
24	3	X-AHCP	ANGLE HANDRAIL CORNER PLATE		12.92	38.76
					TOTAL WT. #	2810.05

DETAIL A

DETAIL B

DETAIL C

DETAIL D

TOLERANCE NOTES

TOLERANCES ON DIMENSIONS, UNLESS OTHERWISE NOTED ARE:
 SAWED, SHEARED AND GAS CUT EDGES ($\pm 0.030"$)
 DRILLED AND GAS CUT HOLES ($\pm 0.030"$) - NO CONING OF HOLES
 LASER CUT EDGES AND HOLES ($\pm 0.010"$) - NO CONING OF HOLES
 BENDS ARE $\pm 1/2$ DEGREE
 ALL OTHER MACHINING ($\pm 0.030"$)
 ALL OTHER ASSEMBLY ($\pm 0.060"$)

PROPRIETARY NOTE:
 THE DATA AND TECHNIQUES CONTAINED IN THIS DRAWING ARE PROPRIETARY INFORMATION OF VALMONT INDUSTRIES AND CONSIDERED A TRADE SECRET. ANY USE OR DISCLOSURE WITHOUT THE CONSENT OF VALMONT INDUSTRIES IS STRICTLY PROHIBITED.

DESCRIPTION
**14' 6" LOW PROFILE PLATFORM
 WITH TWELVE 2-7/8" ANTENNA MOUNTING
 PIPES, AND SUPPORT RAIL**

CPD NO. 4488	DRAWN BY CEK 10/17/2014	ENG. APPROVAL
CLASS 87	SUB 02	DRAWING USAGE CUSTOMER
CHECKED BY BMC 10/17/2014		

SITE PRO 1
 A valmont COMPANY

Locations:
 New York, NY
 Atlanta, GA
 Los Angeles, CA
 Plymouth, IN
 Salem, OR
 Dallas, TX

Engineering Support Team:
 1-888-753-7446

REV	DESCRIPTION OF REVISIONS	CPD	BY	DATE
B	RELOCATED MOUNT PIPE POSITIONS	4488	KC8	5/26/2021
A	CHANGED X-253992 TO X-TBW	4488	CEK	9/20/2018
REVISION HISTORY				

PART NO. RMQLP-4096-HK	1 OF 3
DWG. NO. RMQLP-4096-HK	

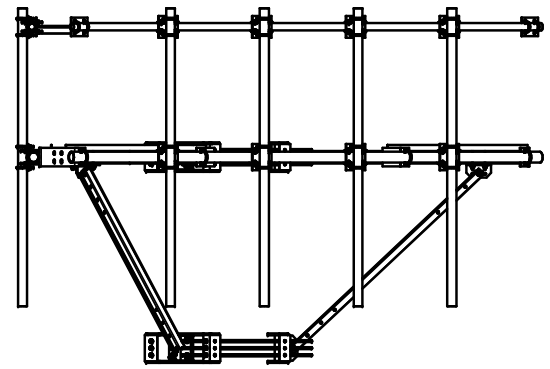
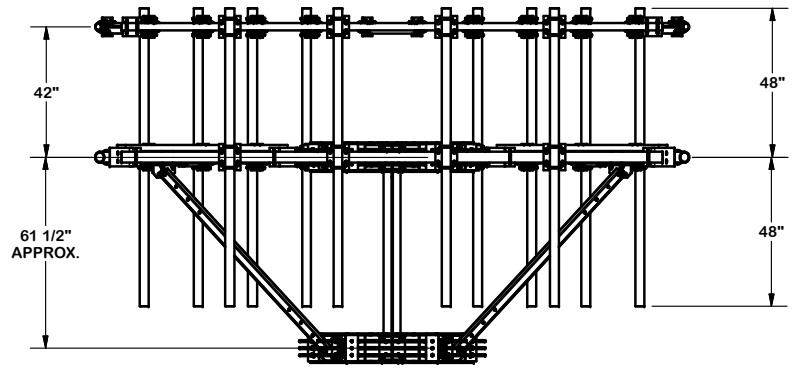
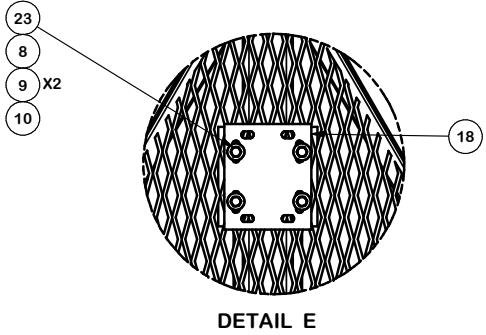
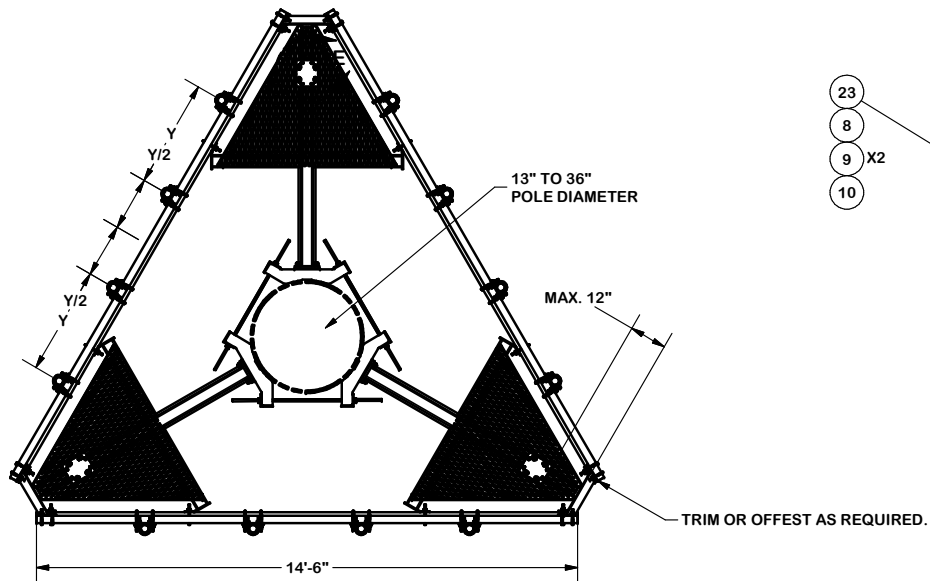

TOLERANCE NOTES

TOLERANCES ON DIMENSIONS, UNLESS OTHERWISE NOTED ARE:
 SAWED, SHEARED AND GAS CUT EDGES ($\pm 0.030"$)
 DRILLED AND GAS CUT HOLES ($\pm 0.030"$) - NO CONING OF HOLES
 LASER CUT EDGES AND HOLES ($\pm 0.010"$) - NO CONING OF HOLES
 BENDS ARE $\pm 1/2$ DEGREE
 ALL OTHER MACHINING ($\pm 0.030"$)
 ALL OTHER ASSEMBLY ($\pm 0.060"$)

PROPRIETARY NOTE:
 THE DATA AND TECHNIQUES CONTAINED IN THIS DRAWING ARE PROPRIETARY INFORMATION OF VALMONT INDUSTRIES AND CONSIDERED A TRADE SECRET. ANY USE OR DISCLOSURE WITHOUT THE CONSENT OF VALMONT INDUSTRIES IS STRICTLY PROHIBITED.

DESCRIPTION
**14' 6" LOW PROFILE PLATFORM
 WITH TWELVE 2-7/8" ANTENNA MOUNTING
 PIPES, AND SUPPORT RAIL**

CPD NO. 4488	DRAWN BY CEK 10/17/2014	ENG. APPROVAL
CLASS 87	SUB 02	DRAWING USAGE CUSTOMER
CHECKED BY BMC 10/17/2014		

SITE PRO 1
 A valmont COMPANY
 Locations:
 New York, NY
 Atlanta, GA
 Los Angeles, CA
 Plymouth, IN
 Salem, OR
 Dallas, TX
 Engineering Support Team:
 1-888-753-7446

REV	DESCRIPTION OF REVISIONS	CPD	BY	DATE
B	RELOCATED MOUNT PIPE POSITIONS	4488	KC8	5/26/2021
A	CHANGED X-253992 TO X-TBW	4488	CEK	9/20/2018

PART NO.	RMQLP-4096-HK	PAGE 2 OF 3
DWG. NO.	RMQLP-4096-HK	

REVISION HISTORY

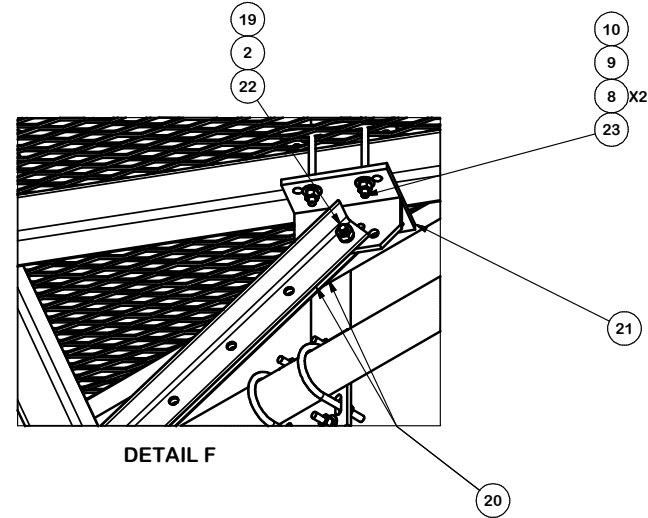
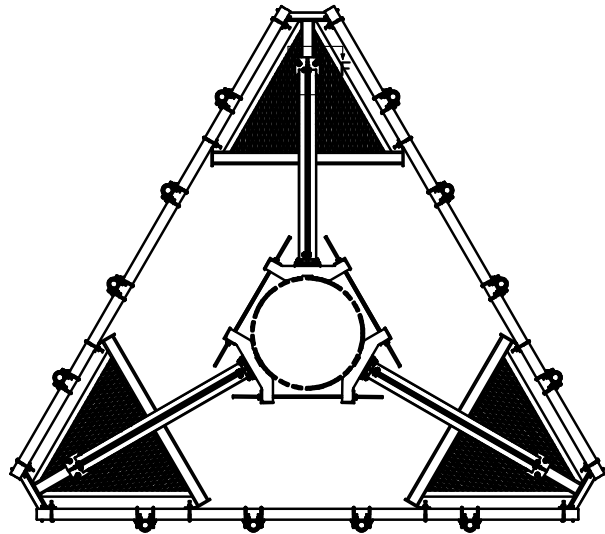
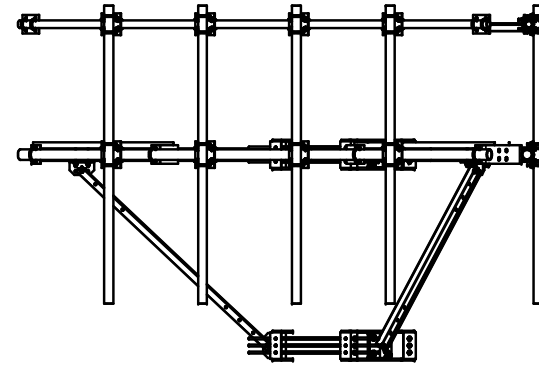
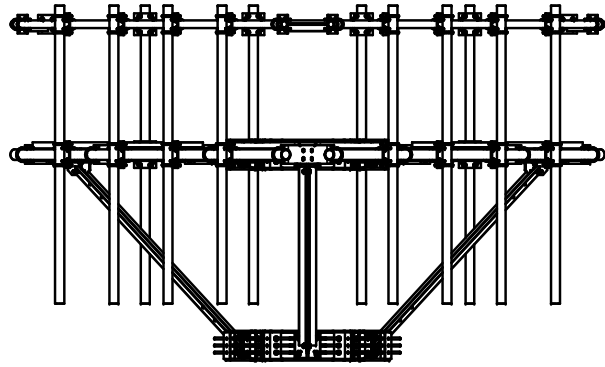

DETAIL F

TOLERANCE NOTES

**TOLERANCES ON DIMENSIONS, UNLESS OTHERWISE NOTED ARE:
 SAWED, SHEARED AND GAS CUT EDGES ($\pm 0.030"$)
 DRILLED AND GAS CUT HOLES ($\pm 0.030"$) - NO CONING OF HOLES
 LASER CUT EDGES AND HOLES ($\pm 0.010"$) - NO CONING OF HOLES
 BENDS ARE $\pm 1/2$ DEGREE
 ALL OTHER MACHINING ($\pm 0.030"$)
 ALL OTHER ASSEMBLY ($\pm 0.060"$)**

PROPRIETARY NOTE:
 THE DATA AND TECHNIQUES CONTAINED IN THIS DRAWING ARE PROPRIETARY INFORMATION OF VALMONT INDUSTRIES AND CONSIDERED A TRADE SECRET. ANY USE OR DISCLOSURE WITHOUT THE CONSENT OF VALMONT INDUSTRIES IS STRICTLY PROHIBITED.

DESCRIPTION
**14' 6" LOW PROFILE PLATFORM
 WITH TWELVE 2-7/8" ANTENNA MOUNTING
 PIPES, AND SUPPORT RAIL**

SITE PRO 1
 Engineering Support Team:
 1-888-753-7446
 Locations:
 New York, NY
 Atlanta, GA
 Los Angeles, CA
 Plymouth, IN
 Salem, OR
 Dallas, TX

REV	DESCRIPTION OF REVISIONS	CPD	BY	DATE
B	RELOCATED MOUNT PIPE POSITIONS	4488	KC8	5/26/2021
A	CHANGED X-253992 TO X-TBW	4488	CEK	9/20/2018

CPD NO. 4488	DRAWN BY CEK 10/17/2014	ENG. APPROVAL
CLASS 87	SUB 02	DRAWING USAGE CUSTOMER
CHECKED BY BMC 10/17/2014		

PART NO. RMQLP-4096-HK	PAGE 3 OF 3
DWG. NO. RMQLP-4096-HK	

REVISION HISTORY