

PARTS LIST						
ITEM	QTY	PART NO.	PART DESCRIPTION	LENGTH	UNIT WT.	NET WT.
1	6	X-LWRM	RING MOUNT WELDMENT		68.81	412.85
2	66	G58LW	5/8" HDG LOCKWASHER		0.03	1.72
3	60	A58NUT	5/8" HDG A325 HEX NUT		0.13	7.79
4	18	G58R-24	5/8" x 24" THREADED ROD (HDG.)		2.09	37.63
5	18	G58R-48	5/8" x 48" THREADED ROD (HDG.)		4.18	75.27
6	24	A58234	5/8" x 2-3/4" HDG A325 HEX BOLT	2 3/4 in	0.36	8.54
7	24	A58FW	5/8" HDG A325 FLATWASHER		0.03	0.82
8	36	X-UB1306	1/2" X 3-5/8" X 6" X 3" U-BOLT (HDG.)		0.83	29.82
9	264	G12FW	1/2" HDG USS FLATWASHER	3/32 in	0.03	9.00
10	252	G12LW	1/2" HDG LOCKWASHER	1/8 in	0.01	3.50
11	252	G12NUT	1/2" HDG HEAVY 2H HEX NUT		0.07	18.05
12	12	P30126	2-7/8" O.D. X 126" SCH. 40 PIPE	126 in	64.63	775.53
13	48	X-UB1300	1/2" X 3" X 5" X 2" U-BOLT (HDG.)		0.70	33.45
14	3	P3150	3-1/2" X 150" (3" SCH 40) GALVANIZED PIPE	150 in	94.80	284.40
15	3	X-SV196	LOW PROFILE PLATFORM CORNER		212.10	636.31
16	3	P2150	2-3/8" O.D. X 150" SCH 40 GALVANIZED PIPE	150 in	45.77	137.31
17	12	SCX2	CROSSOVER PLATE	7 in	4.80	57.56
18	36	X-UB1212	1/2" X 2-1/2" X 4-1/2" X 2" U-BOLT (HDG.)		0.63	22.51
19	15	SCX4	CROSSOVER PLATE	8 1/2 in	6.02	90.32
20	6	G58NUT	5/8" HDG HEAVY 2H HEX NUT		0.13	0.78
21	6	X-253993	PLATFORM REINFORCEMENT KIT ANGLE	52 25/32 in	14.33	85.99
22	6	X-TBW	T-BRACKET WELDMENT		13.60	81.60
23	6	G5802	5/8" x 2" HDG HEX BOLT GR5		0.27	1.62
24	12	G12065	1/2" x 6-1/2" HDG HEX BOLT GR5 FULL THREAD	5 1/2 in	0.41	4.91
25	3	X-AHCP	ANGLE HANDRAIL CORNER PLATE		12.92	38.76
					TOTAL WT. #	2853.68

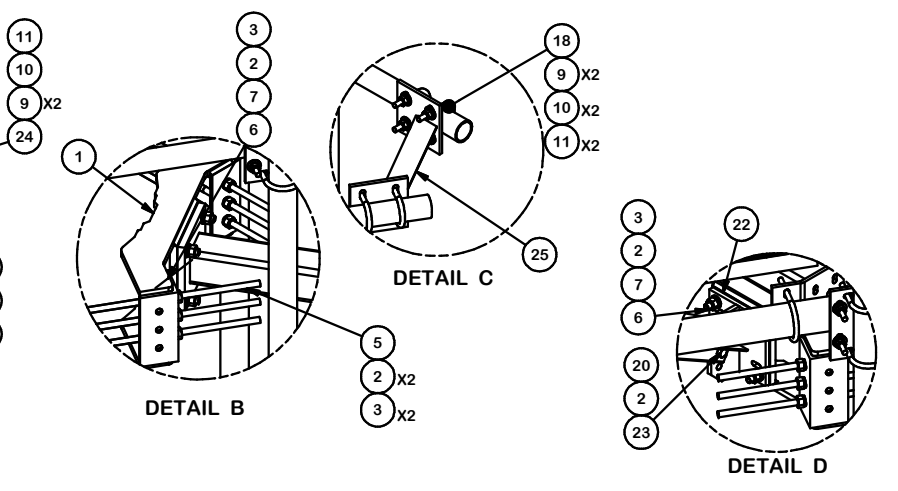

REV	DESCRIPTION OF REVISIONS	CPD	BY	DATE
B	RELOCATED MOUNT PIPE POSITIONS	4488	JET	5/24/2021
A	CHANGED X-253002 TO X-TBW	4488	CEK	9/20/2018
REVISION HISTORY				

TOLERANCE NOTES

TOLERANCES ON DIMENSIONS, UNLESS OTHERWISE NOTED ARE:
 SAWED, SHEARED AND GAS CUT EDGES ($\pm 0.030"$)
 DRILLED AND GAS CUT HOLES ($\pm 0.030"$) - NO CONING OF HOLES
 LASER CUT EDGES AND HOLES ($\pm 0.010"$) - NO CONING OF HOLES
 BENDS ARE $\pm 1/2$ DEGREE
 ALL OTHER MACHINING ($\pm 0.030"$)
 ALL OTHER ASSEMBLY ($\pm 0.060"$)

PROPRIETARY NOTE:
 THE DATA AND TECHNIQUES CONTAINED IN THIS DRAWING ARE PROPRIETARY INFORMATION OF VALMONT INDUSTRIES AND CONSIDERED A TRADE SECRET. ANY USE OR DISCLOSURE WITHOUT THE CONSENT OF VALMONT INDUSTRIES IS STRICTLY PROHIBITED.

DESCRIPTION 12' 6" LOW PROFILE PLATFORM WITH TWELVE 2-7/8" ANTENNA MOUNTING PIPES, AND SUPPORT RAIL		
CPD NO. 4488	DRAWN BY CEK	ENG. APPROVAL 1/5/2017
CLASS 81	SUB 02	DRAWING USAGE CUSTOMER
CHECKED BY BMC		DATE 1/4/2017

 A valmont COMPANY	Locations: New York, NY Atlanta, GA Los Angeles, CA Plymouth, IN Salem, OR Dallas, TX
	Engineering Support Team: 1-888-753-7446
PART NO.	RMQP-40126-HK
DWG. NO.	RMQP-40126-HK

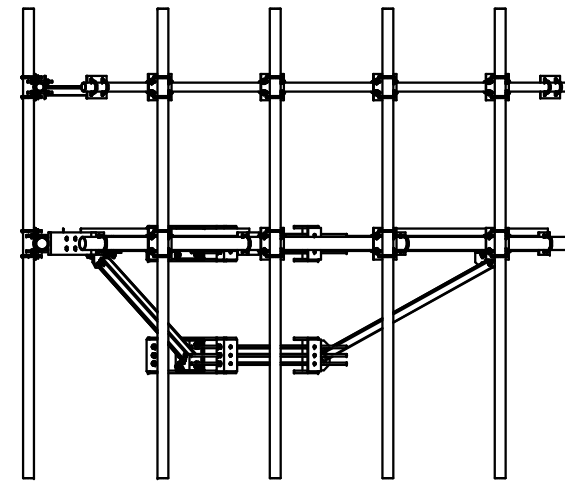
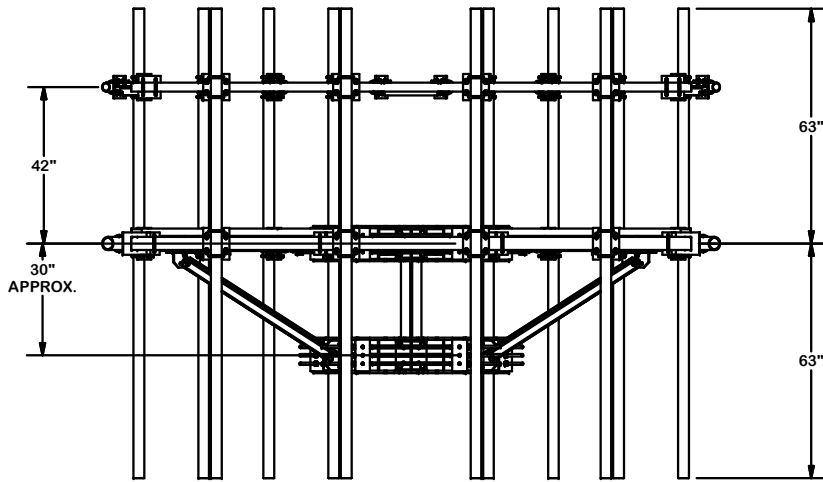
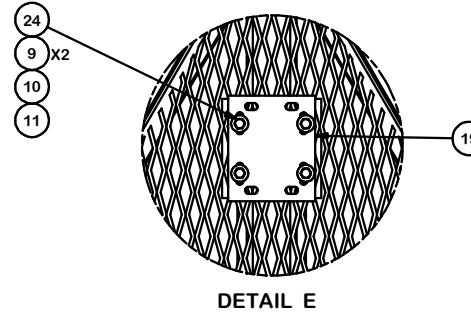
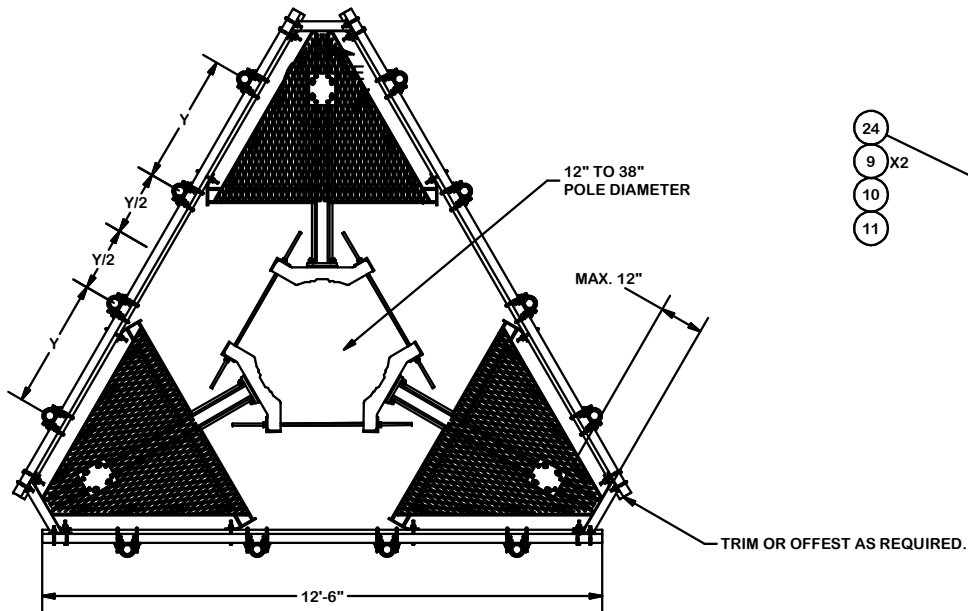

TOLERANCE NOTES

TOLERANCES ON DIMENSIONS, UNLESS OTHERWISE NOTED ARE:
 SAWED, SHEARED AND GAS CUT EDGES ($\pm 0.030"$)
 DRILLED AND GAS CUT HOLES ($\pm 0.030"$) - NO CONING OF HOLES
 LASER CUT EDGES AND HOLES ($\pm 0.010"$) - NO CONING OF HOLES
 BENDS ARE $\pm 1/2$ DEGREE
 ALL OTHER MACHINING ($\pm 0.030"$)
 ALL OTHER ASSEMBLY ($\pm 0.060"$)

PROPRIETARY NOTE:
 THE DATA AND TECHNIQUES CONTAINED IN THIS DRAWING ARE PROPRIETARY INFORMATION OF VALMONT INDUSTRIES AND CONSIDERED A TRADE SECRET. ANY USE OR DISCLOSURE WITHOUT THE CONSENT OF VALMONT INDUSTRIES IS STRICTLY PROHIBITED.

DESCRIPTION
 12' 6" LOW PROFILE PLATFORM
 WITH TWELVE 2-7/8" ANTENNA MOUTING
 PIPES, AND SUPPORT RAIL

SITE PRO 1
 A valmont COMPANY
 Locations:
 New York, NY
 Atlanta, GA
 Los Angeles, CA
 Plymouth, IN
 Salem, OR
 Dallas, TX
 Engineering Support Team:
 1-888-753-7446

REV	DESCRIPTION OF REVISIONS	CPD	BY	DATE
B	RELOCATED MOUNT PIPE POSITIONS	4488	JET	5/24/2021
A	CHANGED X-253002 TO X-TBW	4488	CEK	9/20/2018

CPD NO.	DRAWN BY	ENG. APPROVAL
4488	CEK	1/5/2017
CLASS	SUB	DRAWING USAGE
81	02	CUSTOMER
CHECKED BY	DATE	
BMC	1/4/2017	

PART NO.	DWG. NO.
RMQP-40126-HK	RMQP-40126-HK

REVISION HISTORY

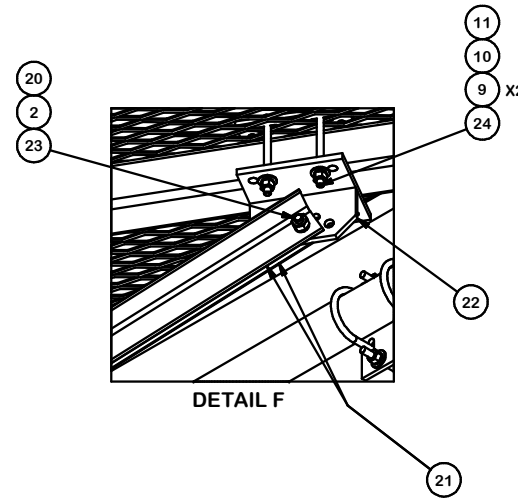
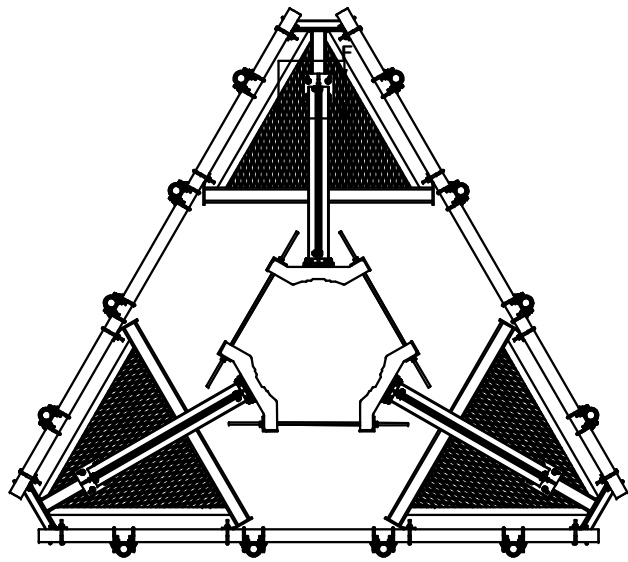
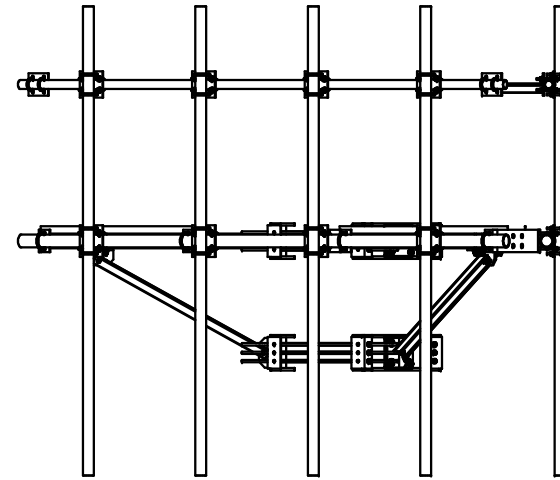
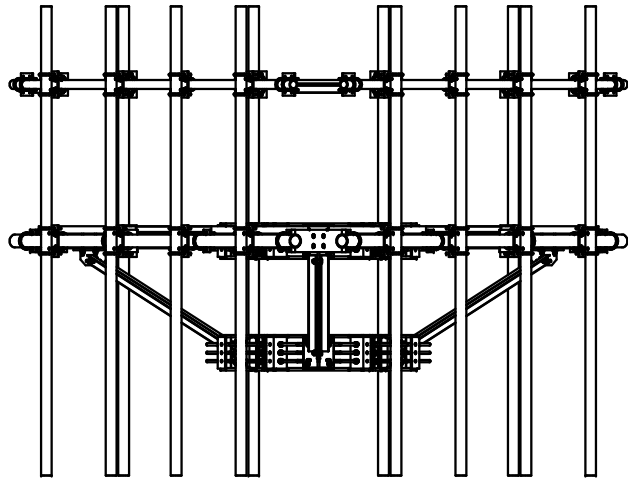

TOLERANCE NOTES

TOLERANCES ON DIMENSIONS, UNLESS OTHERWISE NOTED ARE:
 SAWED, SHEARED AND GAS CUT EDGES ($\pm 0.030"$)
 DRILLED AND GAS CUT HOLES ($\pm 0.030"$) - NO CONING OF HOLES
 LASER CUT EDGES AND HOLES ($\pm 0.010"$) - NO CONING OF HOLES
 BENDS ARE $\pm 1/2$ DEGREE
 ALL OTHER MACHINING ($\pm 0.030"$)
 ALL OTHER ASSEMBLY ($\pm 0.060"$)

PROPRIETARY NOTE:
 THE DATA AND TECHNIQUES CONTAINED IN THIS DRAWING ARE PROPRIETARY INFORMATION OF VALMONT INDUSTRIES AND CONSIDERED A TRADE SECRET. ANY USE OR DISCLOSURE WITHOUT THE CONSENT OF VALMONT INDUSTRIES IS STRICTLY PROHIBITED.

DESCRIPTION
**12' 6" LOW PROFILE PLATFORM
 WITH TWELVE 2-7/8" ANTENNA MOUTING
 PIPES, AND SUPPORT RAIL**

CPD NO. 4488	DRAWN BY CEK	1/5/2017	ENG. APPROVAL
CLASS 81	SUB 02	DRAWING USAGE CUSTOMER	CHECKED BY BMC
		1/4/2017	



Locations:
 New York, NY
 Atlanta, GA
 Los Angeles, CA
 Plymouth, IN
 Salem, OR
 Dallas, TX

Engineering
 Support Team:
 1-888-753-7446

PART NO.	RMQP-40126-HK	PAGE 3 OF 3
DWG. NO.	RMQP-40126-HK	

REV	DESCRIPTION OF REVISIONS	CPD	BY	DATE
B	RELOCATED MOUNT PIPE POSITIONS	4488	JET	5/24/2021
A	CHANGED X-253002 TO X-TBW	4488	CEK	9/20/2018

REVISION HISTORY