

PARTS LIST						
ITEM	QTY	PART NO.	PART DESCRIPTION	LENGTH	UNIT WT.	NET WT.
1	3	X-LWRM	RING MOUNT WELDMENT		68.81	206.42
2	9	G58R-48	5/8" x 48" THREADED ROD (HDG.)		0.40	3.59
2	9	G58R-24	5/8" x 24" THREADED ROD (HDG.)		0.40	3.59
3	3	X-SV196	LOW PROFILE PLATFORM CORNER		212.10	636.31
4	12	A58234	5/8" x 2-3/4" HDG A325 HEX BOLT	2.75	0.36	4.27
5	12	A58FW	5/8" HDG A325 FLATWASHER		0.03	0.41
6	30	G58LW	5/8" HDG LOCKWASHER		0.03	0.78
7	30	A58NUT	5/8" HDG A325 HEX NUT		0.13	3.90
8	3	P3150	3-1/2" X 150" SCH 40 GALVANIZED PIPE	150.000 in	94.80	284.40
9	36	X-UB1306	1/2" X 3-5/8" X 6" X 3" U-BOLT (HDG.)		0.26	9.25
10	120	G12FW	1/2" HDG USS FLATWASHER		0.03	4.09
11	120	G12LW	1/2" HDG LOCKWASHER		0.01	1.67
12	120	G12NUT	1/2" HDG HEAVY 2H HEX NUT		0.07	8.60
13	12	X-SP219	SMALL SUPPORT CROSS PLATE	8.250 in	8.61	103.33
14	24	X-UB1212	1/2" X 2-1/2" X 4-1/2" X 2" U-BOLT (HDG.)		0.26	6.17
15	12	B	ANTENNA MOUNTING PIPE	C	D	E

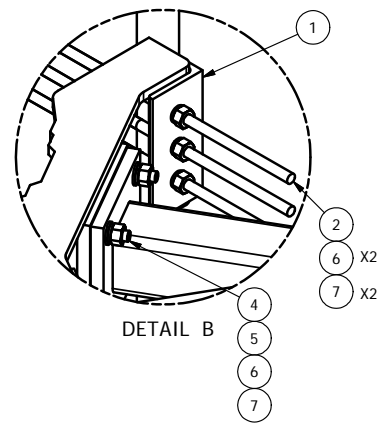
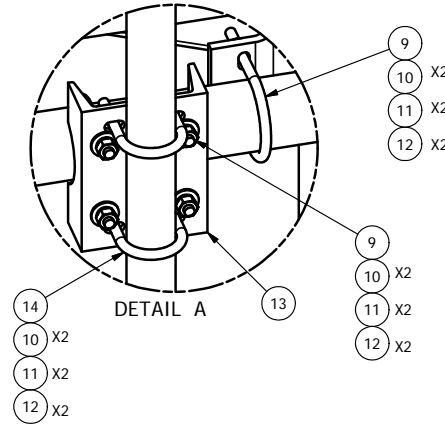

2-3/8" O.D. VERTICAL MOUNTING PIPES					
ASSEMBLY NO. "A"	PART NO. "B"	LENGTH, "C"	UNIT WEIGHT, "D"	NET WEIGHT, "E"	TOTAL WEIGHT
RMQP-463	P263	63"	20.18	242.16	1591.11
RMQP-472	P272	72"	23.07	276.84	1625.79
RMQP-484	P284	84"	26.91	322.92	1671.87
RMQP-496	P296	96"	30.76	369.12	1718.07
RMQP-4126	P2126	126"	40.75	489.00	1837.95

REV	DESCRIPTION OF REVISIONS	CPD	BY	DATE
A	ADDED 10' 6" ANTENNA MOUNTING PIPES	CEK		7/9/2015
REVISION HISTORY				

**TOLERANCE NOTE**  
**TOLERANCES ON DIMENSIONS, UNLESS OTHERWISE NOTED ARE: SAWED, SHEARED AND GAS CUT EDGES (± 0.030")**  
**DRILLED AND GAS CUT HOLES (± 0.030") - NO CONING OF HOLES**  
**LASER CUT EDGES AND HOLES (± 0.010") - NO CONING OF HOLES**  
**BENDS ARE ± 1/2 DEGREE - ALL OTHER MACHINING (± 0.030")**  
**ALL OTHER ASSEMBLY (± 0.060")**

**PROPRIETARY NOTE**  
 THE DATA AND TECHNIQUES CONTAINED IN THIS DRAWING ARE PROPRIETARY INFORMATION OF VALMONT INDUSTRIES AND CONSIDERED A TRADE SECRET. ANY USE OR DISCLOSURE WITHOUT THE CONSENT OF VALMONT INDUSTRIES IS STRICTLY PROHIBITED.

**DESCRIPTION**  
 LOW PROFILE CO-LOCATION PLATFORM  
 FOR 12 ANTENNAS WITH 12' 6" FACE WIDTH  
 FOR 12" - 38" DIAMETER POLES

**DRAWN BY**  
 CEK 1/20/2012

**CPD NO.**  
 semb

**DRAWING USAGE**  
 CUSTOMER

**ENG. APPROVAL**  
 BMC

**CHECKED BY**  
 7/9/2015

**SITE PRO 1**  
 Engineering Support Team:  
 1-888-753-7446

**Locations:**  
 New York, NY  
 Atlanta, GA  
 Los Angeles, CA  
 Plymouth, IN  
 Salem, OR  
 Dallas, TX

**PART NO.**  
 SEE ASSEMBLY NO. "A"

**DWG. NO.**  
 RMQP-4XX

**PAGE 2**

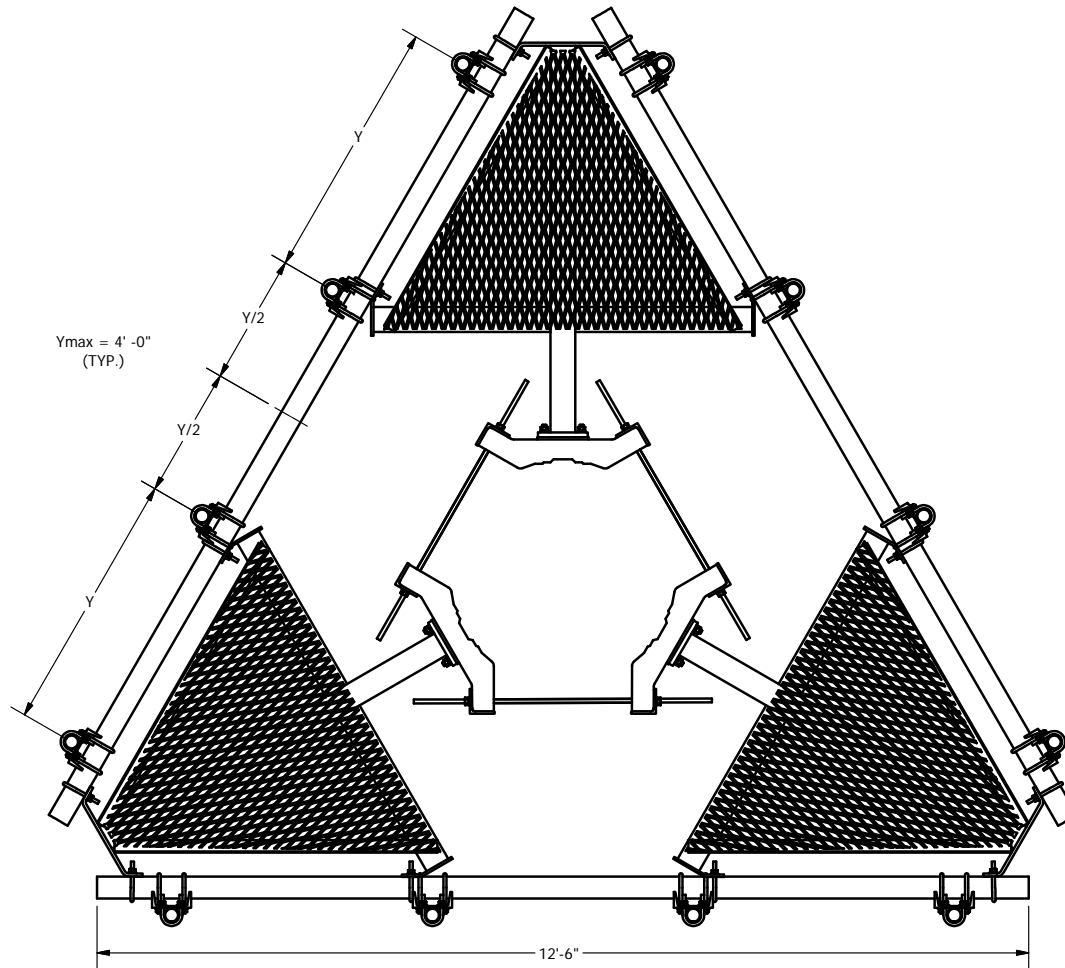

**TOLERANCE NOTE**

**TOLERANCES ON DIMENSIONS, UNLESS OTHERWISE NOTED ARE:  
 SAWED, SHEARED AND GAS CUT EDGES ( $\pm 0.030$ " )  
 DRILLED AND GAS CUT HOLES ( $\pm 0.030$ " ) - NO CONING OF HOLES  
 LASER CUT EDGES AND HOLES ( $\pm 0.010$ " ) - NO CONING OF HOLES  
 BENDS ARE  $\pm 1/2$  DEGREE - ALL OTHER MACHINING ( $\pm 0.030$ " )  
 ALL OTHER ASSEMBLY ( $\pm 0.060$ " )**

**PROPRIETARY NOTE**

**THE DATA AND TECHNIQUES CONTAINED IN THIS DRAWING ARE PROPRIETARY INFORMATION OF VALMONT INDUSTRIES AND CONSIDERED A TRADE SECRET. ANY USE OR DISCLOSURE WITHOUT THE CONSENT OF VALMONT INDUSTRIES IS STRICTLY PROHIBITED.**

**DESCRIPTION**

**LOW PROFILE CO-LOCATION PLATFORM  
 FOR 12 ANTENNAS WITH 12' 6" FACE WIDTH  
 FOR 12" - 38" DIAMETER POLES**



Engineering  
 Support Team:  
 1-888-753-7446

Locations:  
 New York, NY  
 Atlanta, GA  
 Los Angeles, CA  
 Plymouth, IN  
 Salem, OR  
 Dallas, TX

A valmont COMPANY

**DRAWN BY**

**CEK 1/20/2012**

**CPD NO.**

**semb**

**DRAWING USAGE**

**CUSTOMER**

**ENG. APPROVAL**

**CHECKED BY**

**BMC**

**7/9/2015**

**PART NO.**

**SEE ASSEMBLY NO. "A"**

**DWG. NO.**

**RMQP-4XX**

REV	DESCRIPTION OF REVISIONS	CPD	BY	DATE
A	ADDED 10' 6" ANTENNA MOUNTING PIPES		CEK	7/9/2015

**REVISION HISTORY**