

PARTS LIST						
ITEM	QTY	PART NO.	PART DESCRIPTION	LENGTH	UNIT WT.	NET WT.
1	3	X-LWRM	RING MOUNT WELDMENT		68.81	206.42
2	9	G58R-24	5/8" x 24" THREADED ROD (HDG.)	24	0.40	3.59
2	9	G58R-48	5/8" X 48" GALV THREADED ROD		4.39	39.52
3	3	X-SV197-36	SUPPORT ARM WELDMENT - 36"		67.29	201.88
4	12	A58234	5/8" x 2-3/4" HDG A325 HEX BOLT	2.75	0.36	4.27
5	12	A58FW	5/8" HDG A325 FLATWASHER		0.03	0.41
6	42	G58LW	5/8" HDG LOCKWASHER		0.03	1.10
7	24	A58NUT	5/8" HDG A325 HEX NUT		0.13	3.12
8	6	X-UB5458	5/8" X 4-5/8" X 7" X 3" U-BOLT (HDG.)		1.54	9.21
9	18	G58FW	5/8" HDG USS FLATWASHER	.122	0.07	1.27
10	18	G58NUT	5/8" HDG HEAVY 2H HEX NUT		0.13	2.34
11	6	X-SP219	SMALL SUPPORT CROSS PLATE	8.250 in	8.61	51.66
12	3	X-SP216	LARGE SUPPORT CROSS PLATE		22.08	66.23
13	12	X-UB1212	3/8" X 2" X 3" X 1-1/4" U-BOLT (HDG.)		0.60	7.17
14	12	X-UB1306	1/2" X 3-5/8" X 6" X 3" U-BOLT (HDG.)		0.83	9.94
15	12	X-UB1358	1/2" X 3-5/8" X 5-1/2" X 3" U-BOLT (HDG.)		0.77	9.27
16	66	G12NUT	1/2" HDG HEAVY 2H HEX NUT		0.07	4.73
17	66	G12FW	1/2" HDG USS FLATWASHER	0.095	0.03	2.25
18	66	G12LW	1/2" HDG LOCKWASHER	.125	0.01	0.92
19	3	P360	3-1/2" X 60" (3" SCH 40) GALVANIZED PIPE	60	40.25	120.74
20	6	A	B	C	D	

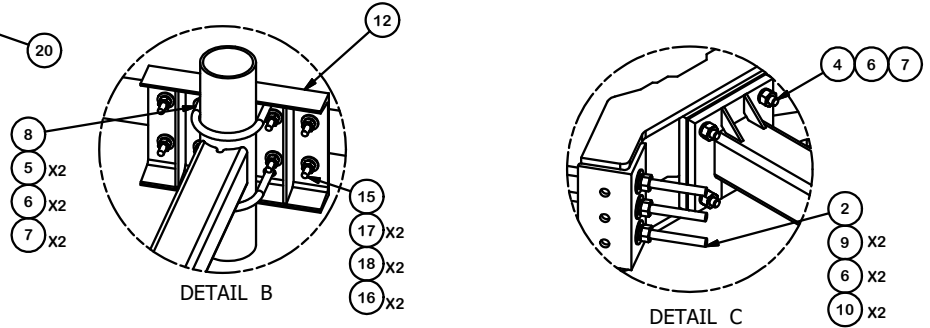

2-3/8" MOUNTING PIPES					
"ASSEMBLY NO."	PART NO. "A"	PART DESCRIPTION "B"	LENGTH "C"	UNIT WT. "D"	TOTAL WT.
RMV5-263	P263	2-3/8" O.D. SCH. 40 PIPE	63"	19.22	860.71
RMV5-272	P272	2-3/8" O.D. SCH. 40 PIPE	72"	23.07	883.81
RMV5-284	P284	2-3/8" O.D. SCH. 40 PIPE	84"	26.91	906.85
RMV5-296	P296	2-3/8" O.D. SCH. 40 PIPE	96"	30.76	929.95
RMV5-2120	P2120	2-3/8" O.D. SCH. 40 PIPE	120"	38.81	978.25
RMV5-2126	P2126	2-3/8" O.D. SCH. 40 PIPE	126"	40.75	989.89

REV	DESCRIPTION OF REVISIONS	CPD	BY	DATE
B	ADDED 10' ANTENNA MOUNTING PIPES		CEK	5/24/18
A	REMOVE FLATWASHERS FROM ARM TO CLAMP RING CONNECTION		CEK	11/4/11

REVISION HISTORY

TOLERANCE NOTES

TOLERANCES ON DIMENSIONS, UNLESS OTHERWISE NOTED ARE:
 SAWED, SHEARED AND GAS CUT EDGES ($\pm 0.030"$)
 DRILLED AND GAS CUT HOLES ($\pm 0.030"$) - NO CONING OF HOLES
 LASER CUT EDGES AND HOLES ($\pm 0.010"$) - NO CONING OF HOLES
 BENDS ARE $\pm 1/2$ DEGREE
 ALL OTHER MACHINING ($\pm 0.030"$)
 ALL OTHER ASSEMBLY ($\pm 0.060"$)

PROPRIETARY NOTE:
 THE DATA AND TECHNIQUES CONTAINED IN THIS DRAWING ARE PROPRIETARY INFORMATION OF VALMONT INDUSTRIES AND CONSIDERED A TRADE SECRET. ANY USE OR DISCLOSURE WITHOUT THE CONSENT OF VALMONT INDUSTRIES IS STRICTLY PROHIBITED.

DESCRIPTION			
MONOPOLE TRIPLE T-ARM FOR 6 ANTENNAS			
CPD NO.	DRAWN BY	ENG. APPROVAL	
4543	CEK	4/15/2011	
CLASS	SUB	DRAWING USAGE	CHECKED BY
81	01	CUSTOMER	BMC

Valmont COMM

Locations:
 New York, NY
 Atlanta, GA
 Los Angeles, CA
 Plymouth, IN
 Salem, OR
 Dallas, TX

Engineering Support Team:
 1-888-753-7446

PART NO.	SEE "ASSEMBLY NO."
DWG. NO.	RMV5-2XX

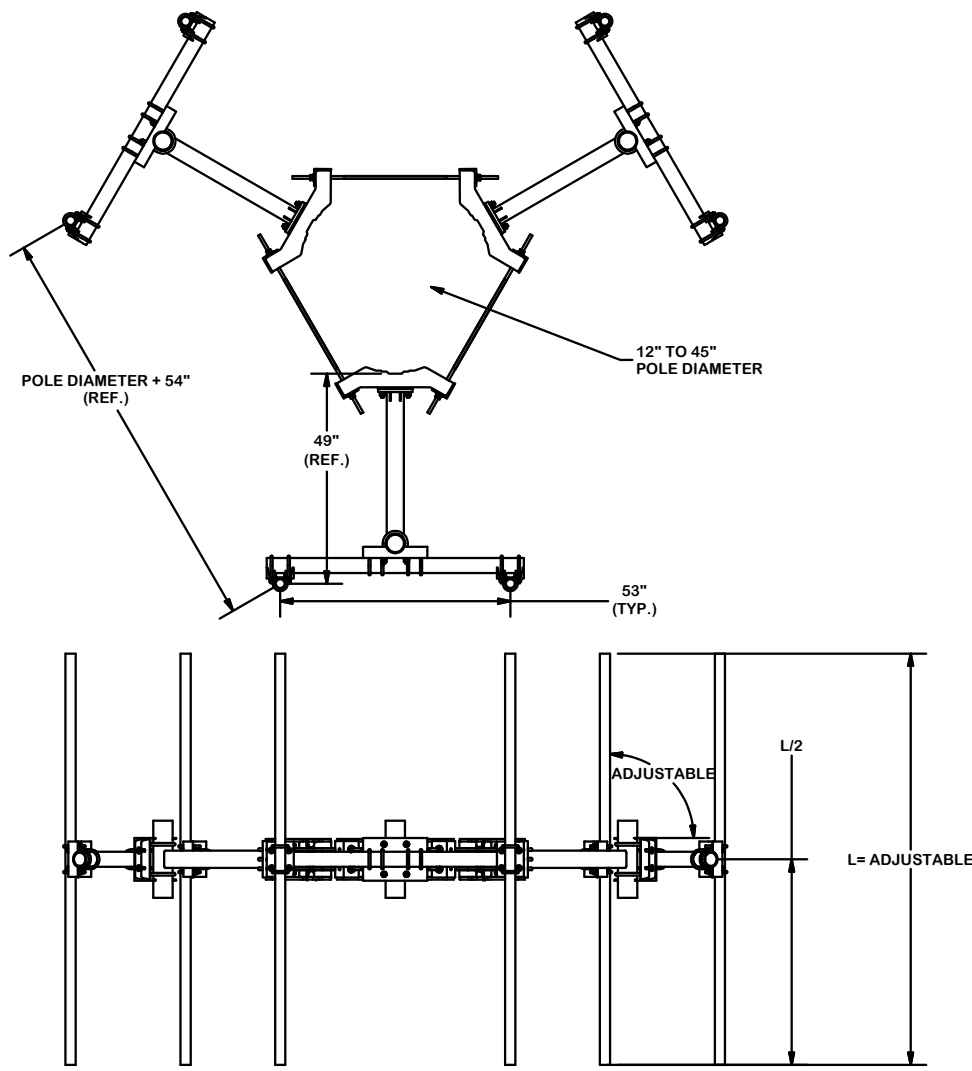

TOLERANCE NOTES

TOLERANCES ON DIMENSIONS, UNLESS OTHERWISE NOTED ARE:
 SAWED, SHEARED AND GAS CUT EDGES ($\pm 0.030"$)
 DRILLED AND GAS CUT HOLES ($\pm 0.030"$) - NO CONING OF HOLES
 LASER CUT EDGES AND HOLES ($\pm 0.010"$) - NO CONING OF HOLES
 BENDS ARE $\pm 1/2$ DEGREE
 ALL OTHER MACHINING ($\pm 0.030"$)
 ALL OTHER ASSEMBLY ($\pm 0.060"$)

PROPRIETARY NOTE:
 THE DATA AND TECHNIQUES CONTAINED IN THIS DRAWING ARE PROPRIETARY INFORMATION OF VALMONT INDUSTRIES AND CONSIDERED A TRADE SECRET. ANY USE OR DISCLOSURE WITHOUT THE CONSENT OF VALMONT INDUSTRIES IS STRICTLY PROHIBITED.

DESCRIPTION
 MONOPOLE TRIPLE T-ARM
 FOR 6 ANTENNAS



Locations:
 New York, NY
 Atlanta, GA
 Los Angeles, CA
 Plymouth, IN
 Salem, OR
 Dallas, TX
 Engineering Support Team:
 1-888-753-7446

B	ADDED 10" ANTENNA MOUNTING PIPES	CEK	5/24/18
A	REMOVE FLATWASHERS FROM ARM TO CLAMP RING CONNECTION	CEK	11/4/11
REV	DESCRIPTION OF REVISIONS	CPD	BY DATE
REVISION HISTORY			

CPD NO.	4543	DRAWN BY	CEK 4/15/2011	ENG. APPROVAL	
CLASS	81	SUB	01	DRAWING USAGE	CUSTOMER
				CHECKED BY	BMC 5/24/2018

PART NO.	SEE "ASSEMBLY NO."	PAGE	2 OF 2
DWG. NO.	RMV5-2XX		