

PARTS LIST						
ITEM	QTY	PART NO.	PART DESCRIPTION	LENGTH	UNIT WT.	NET WT.
1	3	X-LWRM	RING MOUNT WELDMENT		68.81	206.42
2	6	X-178627	BENT EXTENSION BRACKET		15.80	94.79
3	3	X-SV196	LOW PROFILE PLATFORM CORNER		212.10	636.31
4	9	G58R-24	5/8" x 24" THREADED ROD (HDG.)		0.40	3.59
4	9	G58R-48	5/8" x 48" THREADED ROD (HDG.)		0.40	3.59
5	12	A58234	5/8" x 2-3/4" HDG A325 HEX BOLT	2 3/4 in	0.36	4.27
6	18	A5802	5/8" x 2" HDG A325 HEX BOLT		0.27	4.89
7	30	A58FW	5/8" HDG A325 FLATWASHER		0.03	1.02
8	30	G58LW	5/8" HDG LOCKWASHER		0.03	0.78
9	48	A58NUT	5/8" HDG A325 HEX NUT		0.13	6.23
10	12	X-UB1306	1/2" X 3-5/8" X 6" X 3" U-BOLT (HDG.)		0.26	3.08
11	24	G12FW	1/2" HDG USS FLATWASHER		0.03	0.82
12	24	G12LW	1/2" HDG LOCKWASHER		0.01	0.33
13	24	G12NUT	1/2" HDG HEAVY 2H HEX NUT		0.07	1.72
15	3	P3174	3-1/2" X 174" SCH 40 GALVANIZED PIPE	174 in	109.97	329.90
					TOTAL WT. #	1353.88

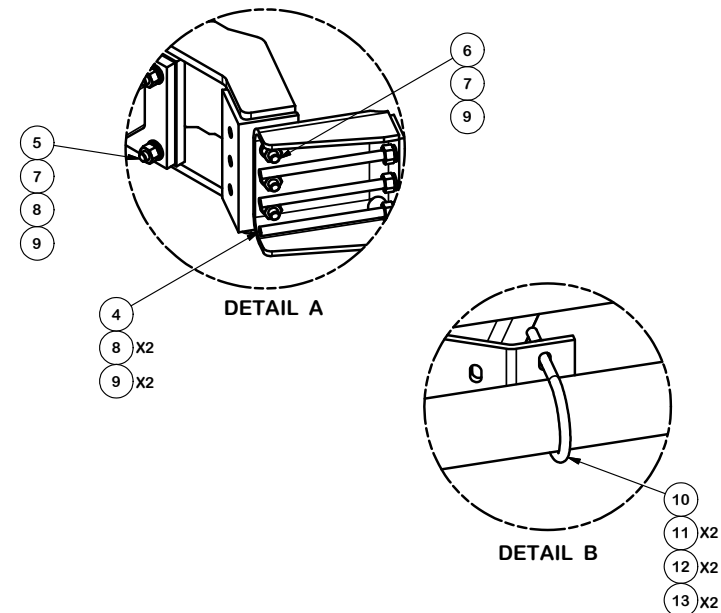

**TOLERANCE NOTES**

TOLERANCES ON DIMENSIONS, UNLESS OTHERWISE NOTED ARE:  
 SAWED, SHEARED AND GAS CUT EDGES ( $\pm 0.030"$ )  
 DRILLED AND GAS CUT HOLES ( $\pm 0.030"$ ) - NO CONING OF HOLES  
 LASER CUT EDGES AND HOLES ( $\pm 0.010"$ ) - NO CONING OF HOLES  
 BENDS ARE  $\pm 1/2$  DEGREE  
 ALL OTHER MACHINING ( $\pm 0.030"$ )  
 ALL OTHER ASSEMBLY ( $\pm 0.060"$ )

PROPRIETARY NOTE:  
 THE DATA AND TECHNIQUES CONTAINED IN THIS DRAWING ARE PROPRIETARY INFORMATION OF VALMONT INDUSTRIES AND CONSIDERED A TRADE SECRET. ANY USE OR DISCLOSURE WITHOUT THE CONSENT OF VALMONT INDUSTRIES IS STRICTLY PROHIBITED.

DESCRIPTION  
 LOW PROFILE CO-LOCATION PLATFORM  
 WITH 14' 6" FACE WIDTH  
 FOR 30" - 60" DIAMETER POLES



Engineering Support Team:  
 1-888-753-7446

Locations:  
 New York, NY  
 Atlanta, GA  
 Los Angeles, CA  
 Plymouth, IN  
 Salem, OR  
 Dallas, TX

CPD NO.	DRAWN BY CEK	ENG. APPROVAL 7/9/2015
CLASS 81	SUB 01	DRAWING USAGE CUSTOMER
	CHECKED BY BMC	7/9/2015

PART NO. RMVP-NP	1 OF 1
DWG. NO. RMVP-NP	