

VARIABLE PIPE LENGTH					
ASSEMBLY "A"	PART NO. "B"	LENGTH "C"	UNIT WT. "D"	NET WT. "E"	TOTAL WEIGHT
SP216-12-NS	P3150	12'-6" [150"]	94.92	94.92	124.0
SP216-14-NS	P3174	14'-6" [174"]	110.11	110.11	139.19

PARTS LIST						
ITEM	QTY	PART NO.	PART DESCRIPTION	LENGTH	UNIT WT.	NET WT.
1	1	X-SP216	LARGE SUPPORT CROSS PLATE		20.83	20.83
2	4	X-UB1306	1/2" X 3-5/8" X 6" X 3" U-BOLT (HDG.)		0.83	3.31
3	2	X-UB5458	5/8" X 4-5/8" X 7" X 3" U-BOLT (HDG.)		0.66	1.31
4	8	G12NUT	1/2" HDG HEAVY 2H HEX NUT		0.07	0.57
5	8	G12FW	1/2" HDG USS FLATWASHER		0.03	0.27
6	8	G12LW	1/2" HDG LOCKWASHER		0.01	0.11
7	4	G58NUT	5/8" HDG HEAVY 2H HEX NUT		0.13	0.52
8	1	"B"	3-1/2" OD SCH 40 GALVANIZED PIPE	"C"	"D"	"E"
9	4	G58LW	5/8" HDG LOCKWASHER		0.03	0.10
10	4	G58FW	5/8" HDG USS FLATWASHER		0.07	0.28

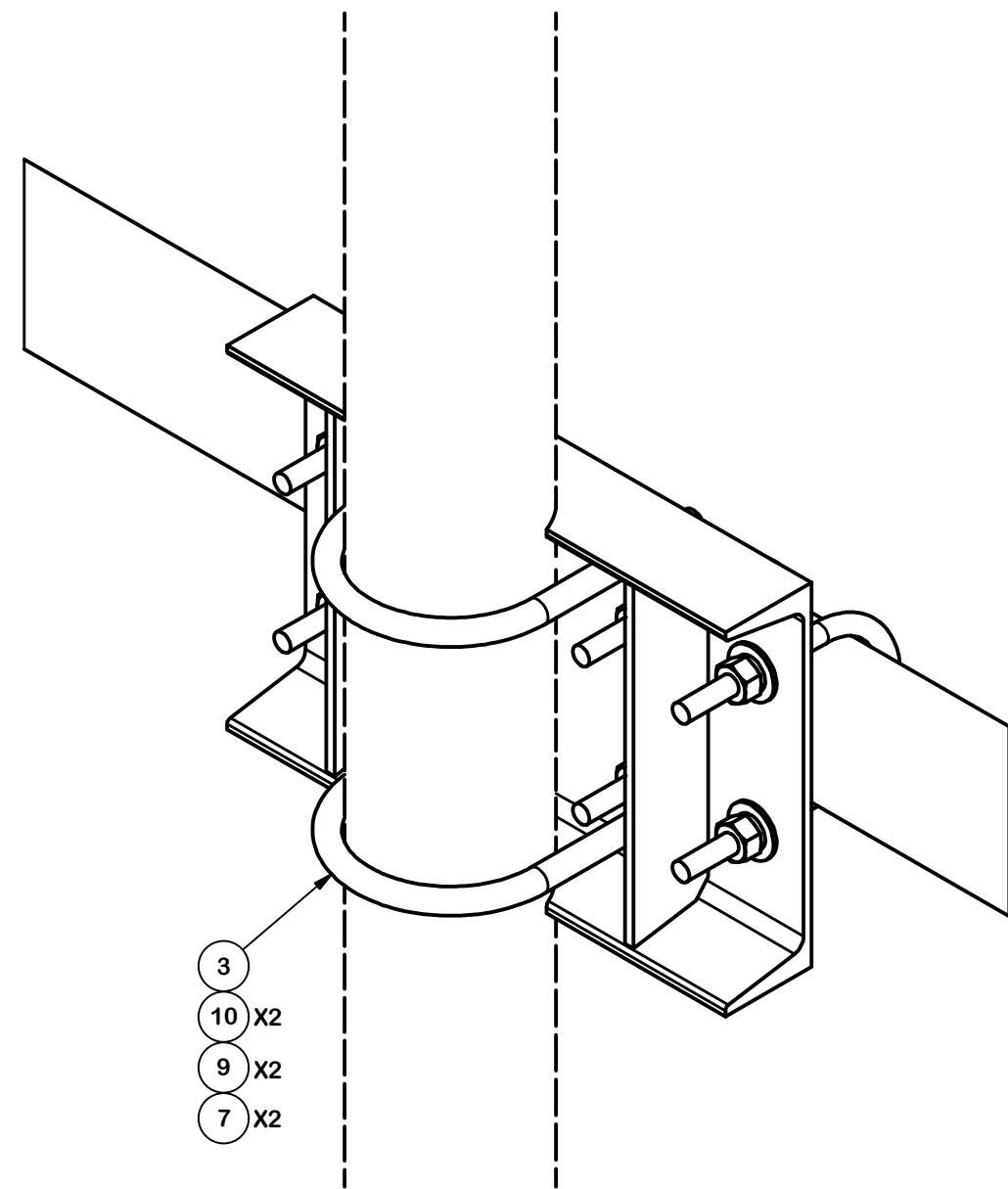
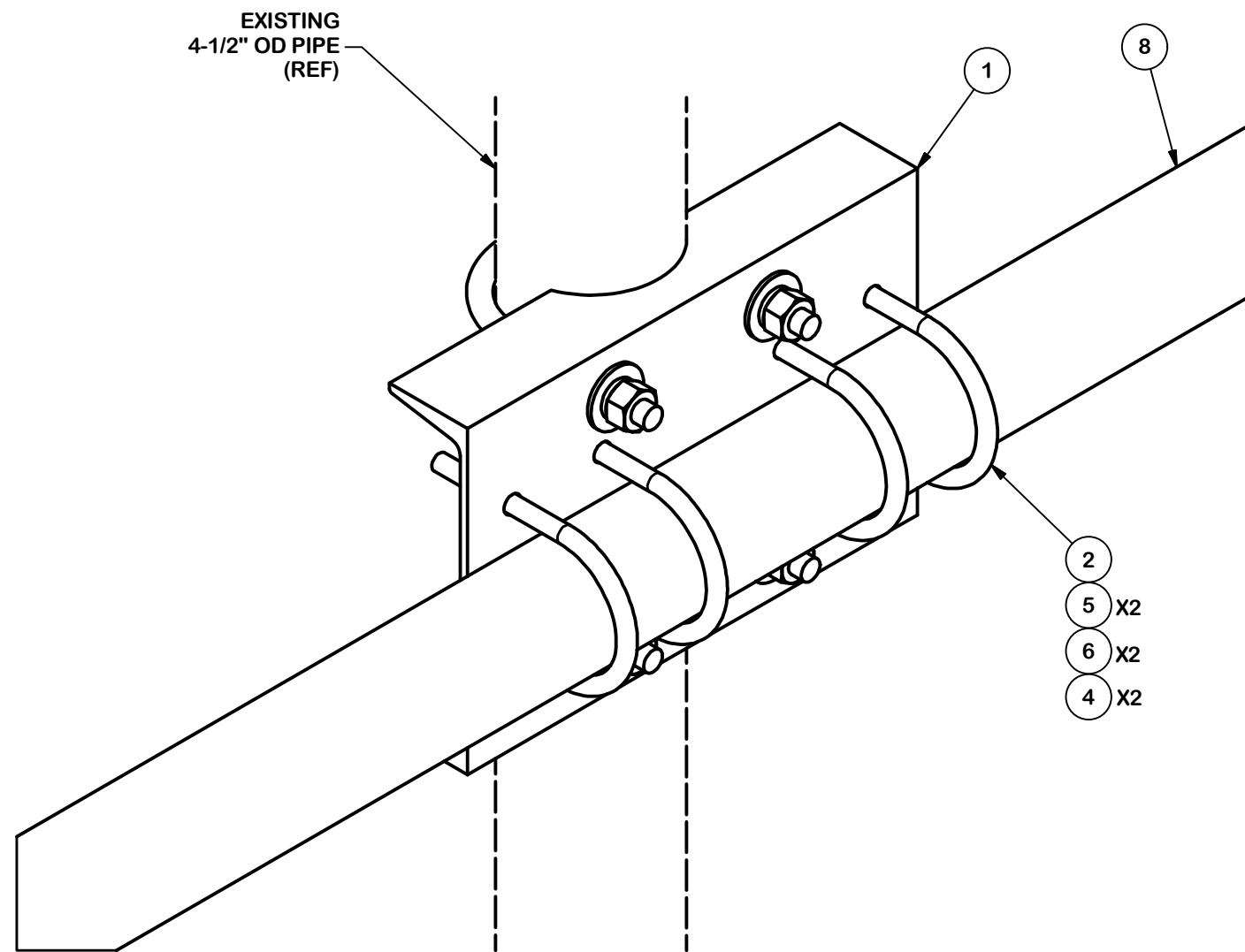

FINISH:
HOT DIP GALVANIZED.

TOLERANCE NOTES

TOLERANCES ON DIMENSIONS, UNLESS OTHERWISE NOTED ARE:
 SAWED, SHEARED AND GAS CUT EDGES ($\pm 0.030"$)
 DRILLED AND GAS CUT HOLES ($\pm 0.030"$) - NO CONING OF HOLES
 LASER CUT EDGES AND HOLES ($\pm 0.010"$) - NO CONING OF HOLES
 BENDS ARE $\pm 1/2$ DEGREE
 ALL OTHER MACHINING ($\pm 0.030"$)
 ALL OTHER ASSEMBLY ($\pm 0.060"$)

PROPRIETARY NOTE:
 THE DATA AND TECHNIQUES CONTAINED IN THIS DRAWING ARE PROPRIETARY INFORMATION OF VALMONT INDUSTRIES AND CONSIDERED A TRADE SECRET. ANY USE OR DISCLOSURE WITHOUT THE CONSENT OF VALMONT INDUSTRIES IS STRICTLY PROHIBITED.

DESCRIPTION
CELLULAR PIPE FRAME

CPD NO.	DRAWN BY	ENG. APPROVAL
	KC8 8/7/2012	
CLASS	SUB	DRAWING USAGE
81	01	CUSTOMER
		CHECKED BY
		CEK 1/23/2013

SITE PRO 1
 A valmont COMPANY

Engineering Support Team:
 1-888-753-7446

Locations:
 New York, NY
 Atlanta, GA
 Los Angeles, CA
 Plymouth, IN
 Salem, OR
 Dallas, TX

PART NO.	SEE ASSEMBLY "A"
DWG. NO.	SP216-XX-NS